

RP520

DATA REPEATER



Forward

Thanks for using our Power Repeater. Before using this product, please read this manual carefully and check if there's any defect during transportation before use, if so please don't use and inform your supplier immediately.

After-Sales

From the day you purchase our products within a year, if being used properly in accordance with the instruction, and quality problems occur, we provide free repair or replacement services except the following cases:

1. Any defects caused by wrong operations.
2. Any damages caused by unauthorized removal, maintenance, modifying circuit, incorrect connections and replacing chips.
3. Any damages due to transportation, breaking, flood after the purchase.
4. Any damages caused by earthquake, fire, flood, lightning strike etc force majeure of natural disasters.
5. Any damages caused by negligence, inappropriate storing at high temperature and humidity environment or near harmful chemicals.
6. Product has been updated.

Safety warnings

In order to ensure the integrity of the state and use of safe, please follow the instructions on this manual and remind

1. Please don't install this dimmer in lightning, intense magnetic and high-voltage fields.
2. To reduce the risk of component damage and fire caused by short circuit, make sure correct connection
3. Always be sure to mount this unit in an area that will allow proper ventilation to ensure a fitting temperature.
4. Check if the voltage and power adapter suit the dimmer
5. Don't connect cables with power on, make sure a correct connection and no short circuit checked with instrument before power on.
6. Please don't open dimmer cover and operate if problems occur.

Features

- For the power of synchronous change signal amplification
- High power of each output
- High-speed process data, no delay, no flicker
- Acceptable PWM control
- DC12-24V wide voltage input
- CCT two-channel signal control, 15A per channel
- Applicable any LED module

Technical parameters

Input voltage	DC12V~24V
Signal output	CCT two signals
Max Load current	15A/CH*2CH
Output power	360W max(12V) 720W max(24V)
Controller size	L82.4*W91*H25 mm
Package size	L84*W93*H27 mm
G.W.	224g

Dimension

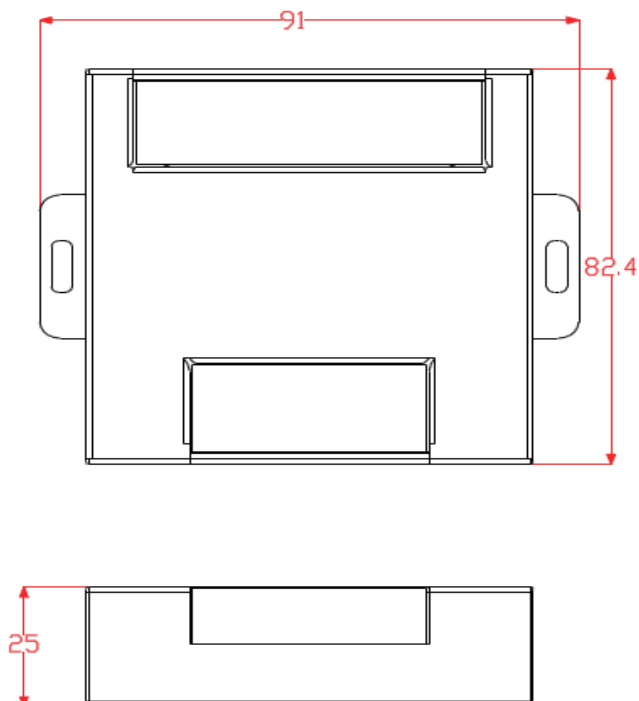

Wiring diagram

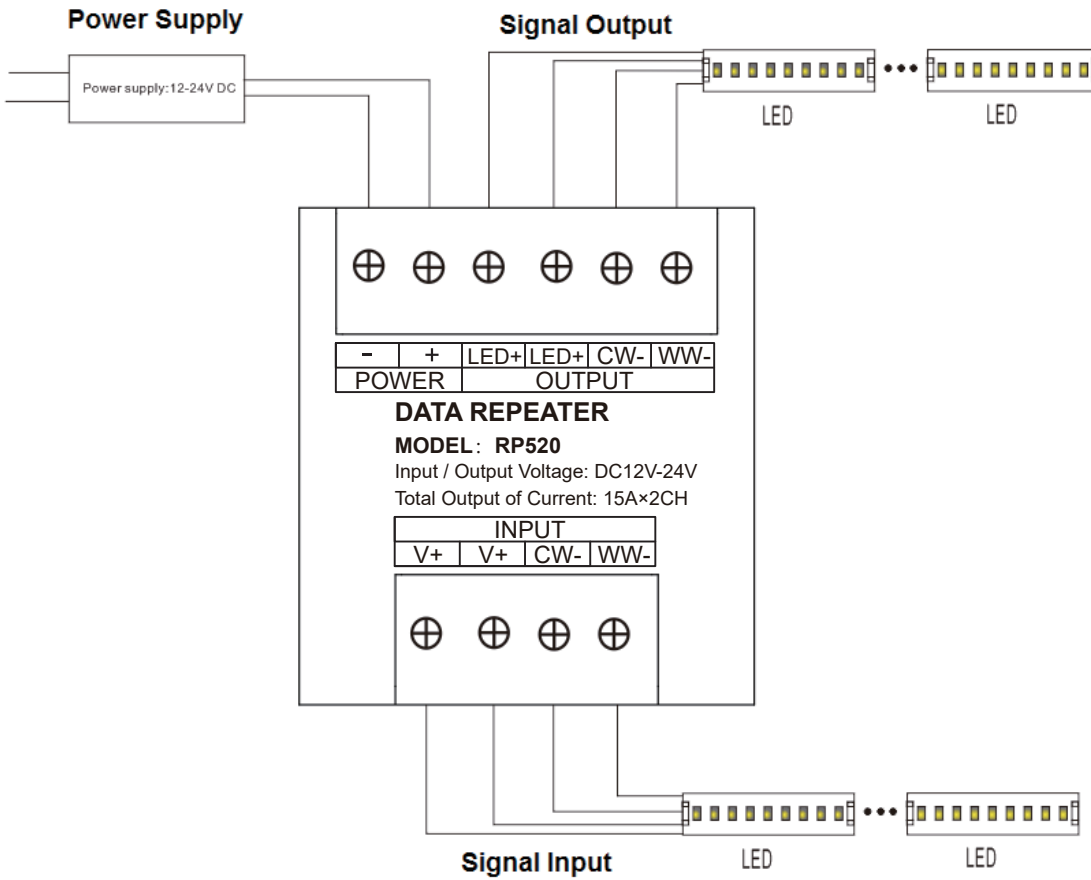

Troubleshooting Guide

Problem	Reason	Solution
No light	<ol style="list-style-type: none"> 1.Switching power supply without power ; 2.Invert “+” and “-” of power supply 3.Wrong connection or not strong 4.LED lamp bad 5.The output is shorted 	<ol style="list-style-type: none"> 1. Check the switching power 2. Corrected 3. Check wiring 4. Replace LED lamp 5.Remove the obstruction and power it back on
LED uneven brightness	<ol style="list-style-type: none"> 1. The output line is too long with voltage drop 2. The wire diameter is too fine with voltage drop 3. Power load is too large 4. Repeater overload 	<ol style="list-style-type: none"> 1.Shorten the line or ring power supply 2.Replace coarse wire 3.Replace larger Power 4.Increase power expander;

Notice: Switch power supply effective power is power supply 80% of the mark, so the user select the power a little higher than the load power of LED light, at least more than 20% .

RP520

数据信号放大器



使用说明:

感谢您选择我公司的功率放大器。在安装使用本产品之前，敬请仔细阅读本手册，确保完全理解本说明书正确使用，以避免造成不必要的损坏。在拆开包装使用前，请查实产品是否存在运输过程所造成的损坏，如果出现损坏，请立即通知你的供应商并不要使用产品。

售后服务:

从购买产品时间起，1年时间内按操作说明正常使用出现质量问题，本公司免费提供维修或更换服务。由于不遵循此说明书说明和下列条款而致使产品损害的，供应商不负责由此引起的任何问题和缺陷，即使在质保期内，由客户承担维修费用。

1. 误操作造成的损坏，如没按照操作说明的误操作。
2. 私自撤除、维修、修改电路、不正确连接以及私自撤换芯片造成的损坏。
3. 购买后由于运输、震荡、摔地造成的损坏。
4. 地震、火灾、洪灾、雷击自然灾害、浸水和不正常电压造成的损坏。
5. 由于疏忽或不恰当如储存在高温和潮湿环境，离有害化学物质附近等不恰当维护造成的损坏。
6. 产品已更新换代。

安全指示:

为了保证产品的完好状态和使用安全,请遵守此说明书上的指示和提醒。

- 1、安装时尽量避免在雷区、强磁场和高压的区域。
- 2、确保接线正确牢固，以免短路损坏部件和触发火灾事故。
- 3、请将控制器安装在通风良好的地方，以保证环境温度适宜。
- 4、使用本产品前，请检查DC电源是否符合产品要求，电源正负极定义是否和产品一致。
- 5、禁止带电接线，检查确认接线正确后，检查无短路，再通电！
- 6、如果发生问题，请勿私自维修。如果有疑问，请联系供应商。

功能特点：

- 处理速度快，无延时，无抖动，同步信号一致性好。
- 每路输出功率大，省去接更多放大器的繁琐工作
- DC12-24V 宽电压范围供电
- 可接受PWM(脉宽调制)控制；
- 用于同步变化信号的功率放大；
- CCT两通道信号控制，每通道15A
- 可适用各种LED 模块；

技术参数：

输入电压	DC12V~24V
信号输入	CCT两路信号
可负载最大电流	15A/路*2路
输出功率	360W max(12V) 720W max(24V)
控制器尺寸	L82.4*W91*H25 mm
包装尺寸	L84*W93*H27 mm
重量（毛重）	224g

尺寸图(mm)：

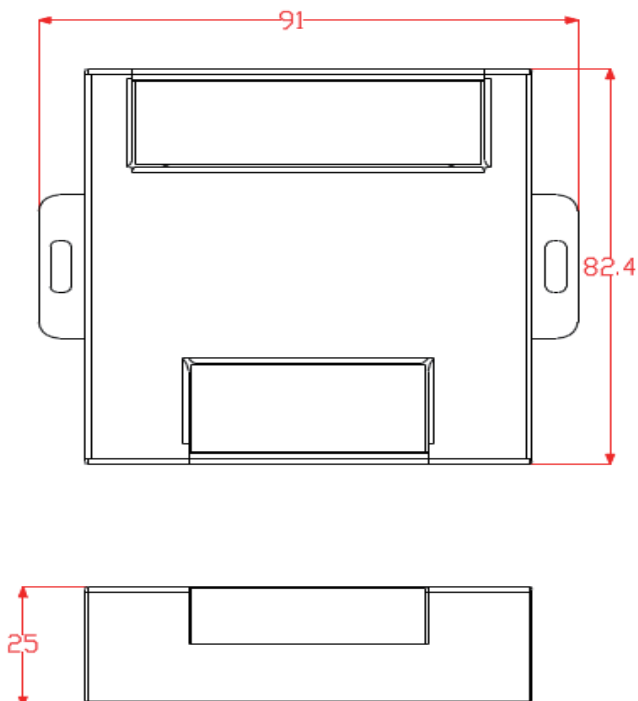

接线图:

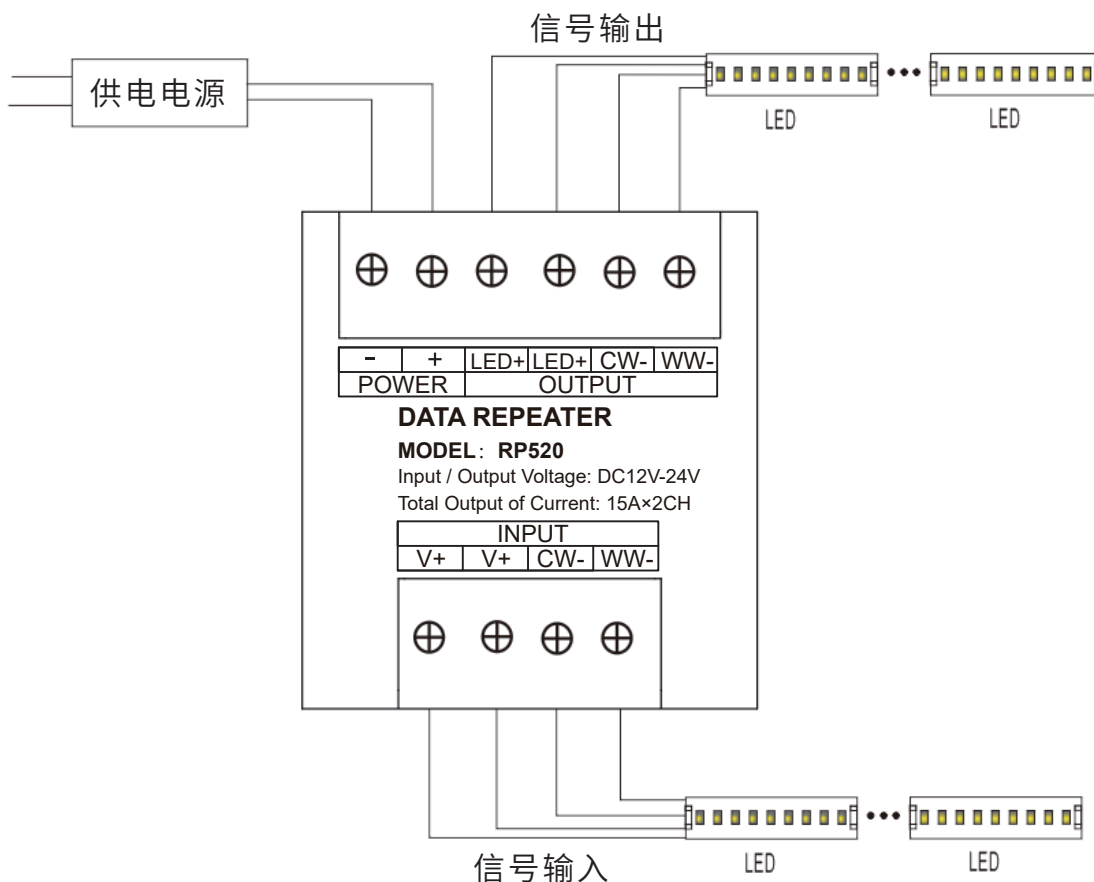

故障分析和解决方法:

故障现象		
不亮	<ol style="list-style-type: none"> 1.开关电源没有电 2.电源正负线接反 3.接错线或不牢固 4.LED灯已不良 5.输出短路 	<ol style="list-style-type: none"> 1. 检查开关电源 2. 改正过来 3. 检查接线 4. 更换LED灯 5. 移除障碍，重新上电
前后LED亮度不均匀	<ol style="list-style-type: none"> 1. 输出线太长有压降 2. 线径太细有压降 3. 电源负荷过大 4. 中继器负荷过大 	<ol style="list-style-type: none"> 1. 缩短线路或环形供电 2. 计算电流更换粗的电线 3. 更换功率大一点的电源 4. 增加功率扩大器

温馨提示：开关电源的有效功率只是电源标记的 80%，所以用户选择电源功率的时候要比 LED 灯负荷功率稍大一点，最少多出 20%以上。